

Working principle

TGF600 Series Thermal Mass Flowmeter measures the gas mass flow base on thermal diffusion theory. It has two filmed RTDs as its sensors, one of which sense the velocity of the gas flow (RH) and the other one will detect the temperature shift of the gas flow (RMG). When the two RTD are in the gas flow ,the RH will be heated while the RMG will sense the temperature changing of the gas flow. More heat will be taken away as the velocity of the gas flow increasing, so the temperature on RH will decline.

Special features

- Direct mass flow or normal flow measurement
- 100:1 turn down ratio in 5 ranges: 0.3~30Nm/s, 0.6Nm/s~60 Nm/s, 0.9~90Nm/s, 1.2~120Nm/s, or 1.5~150Nm/s
- No pressure loss, suitable for pipe in any shape with known sectional area
- For the insertion type, installation and maintenance can be finished on line
- High accuracy data acquisition circuit to ensure outstanding repeatability and accuracy
- High efficiency design of power supply, the total power consumption is only 60mA@24VDC
- 16V~32V wide voltage range input to fit in all electricity environment
- Self-diagnose function plus remote diagnose function, ensure easier trouble-shooting
- Ex-proof version optional
- Bluetooth communication for reading, setting and diagnosis and COMMATE APP
- No mechanical wear part



Specification

Media Compatibility	Air, Nitrogen, O ₂ , CO ₂ , Argon, CH ₄ , Natural gas, biogas, and almost all dry and clean air
Pipe diameter	Insertion: DN25 ~ 2500mm Inline: DN25 ~ 300mm
Flow velocity range	0.3~30Nm/s 0.6~60Nm/s 0.9~90Nm/s 1.2~120Nm/s 1.5~150Nm/s
Accuracy	1.5% RD ± 0.5% FS
Temperature of medium	Standard: -40 ~ +150°C Middle: -40 ~ +250°C High: -40 ~ +450°C
Pressure of medium	Insertion: 1.6 MPa Flanged insertion: 6.3 MPa Flanged in-line: 6.3 MPa
Power supply	AC85~264V or DC16~32V
Response time	1 second
Output	Frequency and 4~20mA as standard
Communication	RS-485 + Bluetooth as standard , 4~20mA@HART as optional
Date displayed	Mass flow, Total flow Volume flow in normal condition
Ingress protection grade	IP65 (GB China)
Ex-proof	NEPSI EX d II c T3 Gb

Insertion type with ball valve
Install/remove the meter without stopping the flow

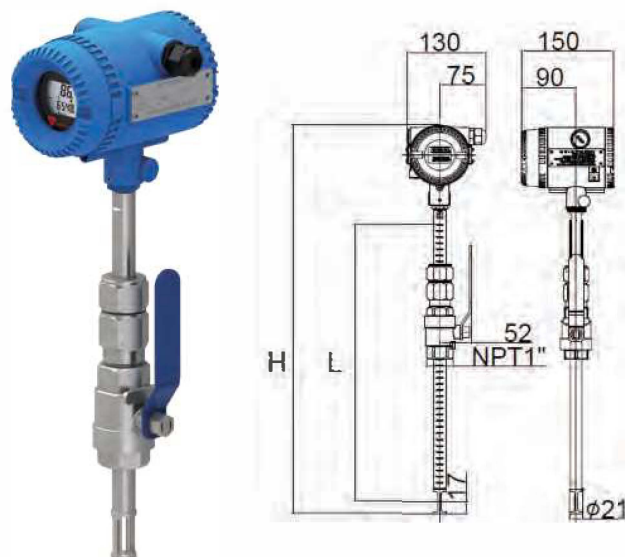

Probe	H	L
290 mm	433.5 mm	255.5 mm
440 mm	583.5 mm	405.5 mm
690 mm	833.5 mm	655.5 mm
1000 mm	1143.5 mm	965.5 mm
1500 mmt	1643.6 mm	1465.5 mm

Max pipe size that each probe can adapt to

Probe length	290mm	440mm	690mm	1000mm	1500mm
T < 50 dgr C	DN150	DN450	DN900	DN1500	DN2500
50 °C < T < 150 °C	/	DN100	DN600	DN1200	DN2200
150 °C < T < 250 °C	/	/	DN400	DN1000	DN2000
250 °C < T < 450 °C	/	/	DN300	DN600	DN1000
T < 122 °F	6"	18"	36"	60"	100"
122 °F < T < 302 °F	/	4"	24"	48"	88"
302 °F < T < 482 °F	/	/	16"	40"	80"
482 °F < T < 842 °F	/	/	12"	24"	40"

Other process connection

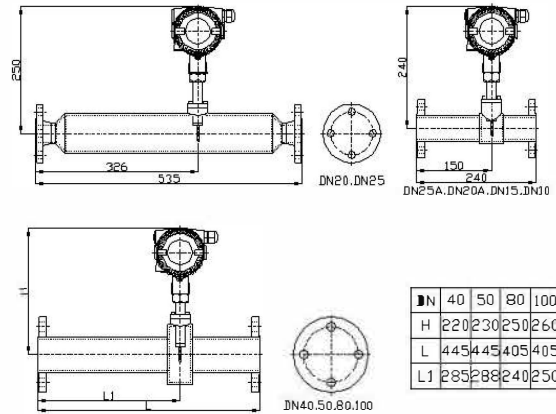

Flanged insertion type

For applications with pressure higher than 1.6MPa

Flanged type

For in-line connection, 1.6 ~ 6.3 MPa and different flanged standard available

Dimension of Flanged type thermal mass flow meter

Standard Volume flow rate range in popular sizes

Pipe size (mm)	Pipe size (inch)	Option 1 (0.3~30 Nm/s)		Standard (0.6~60 Nm/s)		Option 2 (0.9~90 Nm/s)		Option 3 (1.2~120 Nm/s)	
		Min flow Nm ³ /hr	Max flow Nm ³ /hr	Min flow Nm ³ /hr	Max flow Nm ³ /hr	Min flow Nm ³ /hr	Max flow Nm ³ /hr	Min flow Nm ³ /hr	Max flow Nm ³ /hr
25 mm	1"	0.53	53	1.05	105.9	1.58	158.8	2.11	211.8
32 mm	1 1/4"	0.87	86.7	1.73	173.5	2.6	260.3	3.47	347.1
40 mm	1 1/2"	1.36	135.6	2.71	271.1	4.06	406.7	5.42	542.3
50 mm	2"	2.12	211.9	4.23	423.7	6.35	635.5	8.47	847.4
65 mm	2 1/2"	3.58	358.1	7.1	716.1	10.7	1074.1	14.3	1432.2
80 mm	3"	5.42	542.3	10.8	1084.7	16.2	1627.1	21.6	2169.4
100 mm	4"	8.47	847.5	16.9	1694.9	25.4	2542.3	33.8	3389.8
125 mm	5"	13.2	1324.2	26.4	2648.3	39.7	3972.4	52.9	5296.6
150 mm	6"	19.1	1906.8	38.1	3813.5	57.2	5720.3	76.2	7627.1
200 mm	8"	33.9	3389.8	67.7	6779.6	101.6	10169.4	135.5	13559.3
250 mm	10"	53	5296.6	105.9	10593.2	158.8	15889.8	211.8	21186.4
300 mm	12"	76.3	7627.1	152.5	15254.2	228.8	22881.3	305	30508.4

Mode number

The standard model number is usually TGF600-1-2-I2-1-N-T-M-N-1-1-XXXX,
Please reference to the table below for what the model codes stand for.

Mode codes

1	General model	TGF600		Standard
2	Fluid type	1	Air/nitrogen	Standard
		2	Oxygen (sensor will be degreased)	Option
		3	Other (Please advise gas composition)	Option
3	Measurement range	1	0.3~30 Nm/s	Option
		2	0.6~60 Nm/s	Standard
		3	0.9~90 Nm/s	Option
		4	1.2~120 Nm/s	Option
		5	1.5~150 Nm/s	Option
		6	1.8~180 Nm/s	Option
4	Process connection	I1	Insertion type with 290mm probe	Option
		I2	Insertion type with 440mm probe	Standard
		I3	Insertion type with 690mm probe	Option
		I4	Insertion type with 1000mm probe	Option
		I5	Insertion type with 1500mm probe	Option
		F1	Flanged insertion type up to 25 barG (362 psiG)	Option
		F2	Flanged insertion type up to 40 barG (580 psiG)	Option
		F2	Flanged insertion type up to 63 barG (913 psiG)	Option
		D1	Flanged DIN PN16 up to 16 barG (232 psiG) (DN15~DN300)	Option
		D2	Flanged DIN PN25 up to 25 barG (362 psiG) (DN15~DN300)	Option
		D3	Flanged DIN PN40 up to 40 barG (580 psiG) (DN15~DN300)	Option
		D4	Flanged DIN PN63 up to 63 barG (913 psiG) (DN15~DN300)	Option
		C1	Flanged ANSI CL150 up to 16 barG (232 psiG) (0.5 inch~12 inch)	Option
		C2	Flanged ANSI CL300 up to 40 barG (580 psiG) (0.5 inch~12 inch)	Option
		C3	Flanged ANSI CL400 up to 63 barG (913 psiG) (0.5 inch~12 inch)	Option
5	Wet part material	1	316ss sensor with 304ss wet parts	Standard
		2	316ss sensor with 316ss wet parts	Option

6	Medium temp range	N	< 150°C	Standard
		Q	< 250°C	Option
		H	< 450°C (please select remote display also)	Option
7	Transmitter	T	Integral	Standard
		R	Remote	Option
8	Cable grinder	M	M20 x 1.5	Standard
		N	NPT 1/2	Option
9	Ex-proof	N	No Ex-proof	Standard
		1	NEPSI Ex d IIC T3 Gb	Option
10	Transmitter	1	pulse/frequency + 4~20mA + RS485 + Bluetooth	Standard
		2	pulse/frequency + 4~20mA@HART + Bluetooth	Option
11	Power supply	1	13.5~42VDC	Standard
		2	13.5~42VDC with 85~265VAC 50/60Hz power converter	Option
12	Pipe size	xxxx	please use 4 digit pipe size, such as DN50=0050, DN300=0300	xxxx